

## Key Features&Benefits

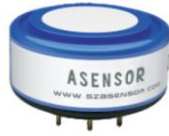

- **Low Power Consumption**
- **High Precision**
- **High Sensitivity**
- **Wide Linear Range**
- **Excellent Repeatability and Stability**

## Applications

**Industrial Safety、 Mining、 Residential Safety、 Emissions、 Environmental Monitoring**

## Technical Specifications

### MEASUREMENT

<b>Operating Principle</b>		3-electrodes electrochemical
<b>Detection Range</b>		0 to 1000ppm
<b>Maximum Overload</b>		1000ppm
<b>Sensitivity</b>		0.13 ± 0.02(uA/ppm)
<b>Baseline Offset(20℃)</b>		-1 to +3ppm equivalent
<b>Baseline Drift(-20~40℃)</b>		<9ppm equivalent
<b>Response Time (T90)</b>		≤25 seconds
<b>Repeatability</b>		1% of signal
<b>Linearity</b>		Linear
<b>Long Term Output Drift</b>		<0.5% signal/month

### ELECTRICAL

<b>Recommended Load Resistor</b>		10Ω
<b>Bias Potential</b>		not required

### ENVIRONMENTAL

<b>Temperature Range</b>		-20℃ to 50℃
<b>Operating Humidity</b>		15 to 90%RH non-condensing
<b>Pressure Range</b>		90 to 110kPa
<b>Storage Temperature</b>		0℃ to 20℃

### LIFETIME

<b>Storage Life</b>		6 months in sealed container
<b>Expected Operating Life</b>		3 years in air
<b>Warranty</b>		18 months from date of despatch

### PHYSICAL CHARACTERISTICS

<b>Weight</b>		11g(approx)
<b>Orientation Sensitivity</b>		None

## Product Dimensions

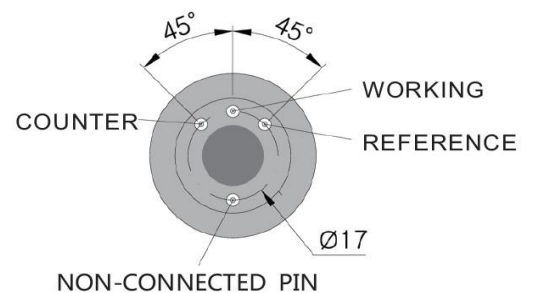
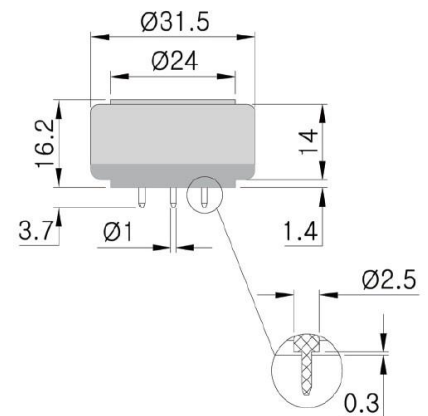

**Note1:** All performance specifications are based upon the following environment conditions: 20℃, 50% relative humidity and 1 atm (1013 mBar or ambient pressure).

**Note2:** PCB sockets are recommended for the sensor pin connection. Soldering to the sensor should be avoided.

## Cross-sensitivity Data (20°C)

- Notes:**
1. Calibration with cross sensitivity gas is not recommended.
  2. The cross sensitivity may fluctuate between +/- 30% and may differ from batch to batch or from sensor's life time.
  3. The cross sensitivities are including but not limited to the above gases. It may also respond to other gases.

Gas	Concentration used (ppm)	DH7-CO-1000 (ppm CO)
H <sub>2</sub>	500	200
H <sub>2</sub> S	50	165
SO <sub>2</sub>	50	10
NO <sub>2</sub>	50	-37
NO	50	18

## Precautions

1. The sensor should be prevented from organic solvents and corrosive gases.
2. The sensor should not be stored in dusty, dirty areas and anaerobic environment.
3. The sensor must not be exposed to very high concentrations of the analyte permanently.
4. Excessive shock or vibration should be prevented to avoid internal damages.
5. The pins should not be broken and bent.
6. Electrolyte leakage can cause damage, please do not disassemble the sensor.
7. The working and reference electrodes should be in short-circuit condition in storage.

### ➔ CONTACT US

Asensor Technologies Co., Ltd  
Address: South Building, No.29 High-tech South  
1st Road, South Area, High-tech Industrial Park,  
Shenzhen, Guangdong  
Email: [zasensor@163.com](mailto:zasensor@163.com)  
Tel: +86-755-26520508  
Fax: +86-755-26520539  
Web site : [www.zasensor.com](http://www.zasensor.com)